

--	--	--	--	--	--	--	--	--	--	--	--	--	--	--	--	--	--	--	--	--

VASAVI COLLEGE OF ENGINEERING (AUTONOMOUS), HYDERABAD

Accredited by NAAC with A++ Grade

B.E. III-Semester Bridge Course Supplementary Examinations, August-2022

Mechanics for Engineers

Time: 3 hours

Max. Marks: 50

Note: Answer all questions from Part-A and any FIVE from Part-B

Part-A (10 × 2 = 20 Marks)

Q. No.	Stem of the question	M	L	CO	PO
1.	What is principle of transmissibility?	2	1	1	1
2.	Decipher the term engineering mechanics	2	1	1	1
3.	List equations of equilibrium for a coplanar concurrent system of forces	2	2	2	1
4.	How many reactions are possible for a ball and socket joint?	2	2	2	1
5.	What is cone of friction?	2	1	3	1
6.	List examples of advantages and disadvantages of friction	2	1	3	1
7.	What is translation motion?	2	2	4	1
8.	What is curvilinear motion?	2	1	4	1
9.	State 'D' Alembert's principle	2	2	5	1
10.	Distinguish the terms kinematics and kinetics	2	2	5	1
Part-B (5 × 6 = 30 Marks)					
11.	In the figure a boom AC is supported by ball and socket joint at C and by cables AE and BD. If the force multiplier of a force F acting from A to E is $F_m = 15 \text{ N/m}$ and that of a force acting from B to D is $P_m = 25 \text{ N/m}$ solve for the component of each force along AC.	6	3	1	1
12.	Determine the amount and direction of the smallest force P required to start the wheel shown in fig over the block. What is the reaction at the block? Weight of the wheel is 200 N. The wheel and the block are on a horizontal ground.	6	2	2	1

13. A horizontal bar of 10m long and of negligible weight rests on rough incline planes as shown in figure. If angle of friction ϕ is 18° identify how close to B may the 200N force be applied before motion impends. 6 3 3 1

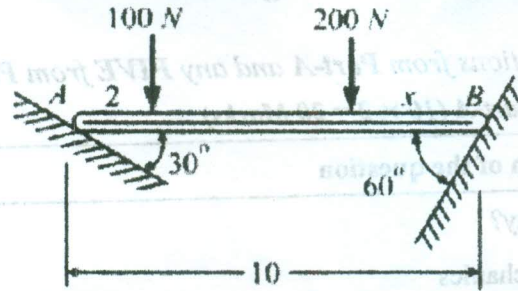

14. A projectile is fired from top of a cliff 125m high with a velocity of 380 m/s directed at 25° to the horizontal. Solve for the range on horizontal plane through the base of the cliff. 6 3 4 1

15. Two blocks A and B are released from rest on 30° inclined plane when they are 18m apart. The coefficient of friction are 0.2 and 0.4 for blocks A and B respectively. Solve for the elapsed time until the blocks touch. Also calculate the acceleration after blocks coming in contact. Compute desired quantities in terms of W_A and W_B . 6 3 5 1

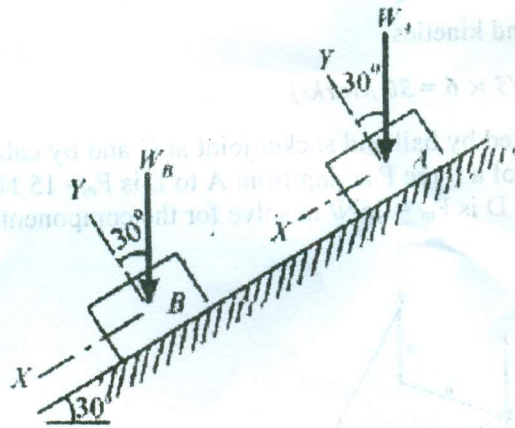

16. a) Find the resultant of the following system of forces 3 2 1 1

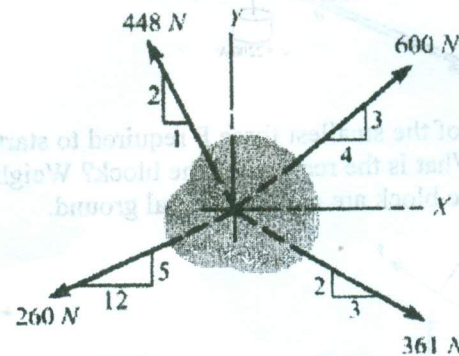

- b) Two cylinders 20N and 40 N are piled in a rectangular ditch as shown in figure. Neglecting friction, determine the reactions at various contact points.

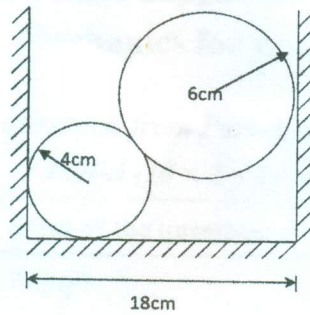

3 2 2 1

17. Answer any *two* of the following:

- a) Determine the minimum weight of block B that will keep it at rest as horizontal force P starts motion of block A which weighs 300N. The angle of friction is 150 between A and B while the coefficient of friction is 0.30 between B and the ground.

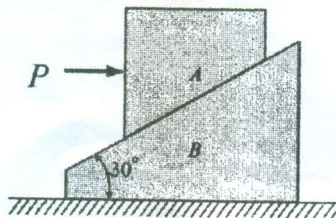

3 3 3 1

- b) Solve for the depth of well if a stone is dropped into a well with no initial velocity and 8 seconds later splash is heard. If the velocity of sound is 220 m/s.

3 1 4 1

- c) The frame of certain machine accelerates rightward at $7/8 g$. As shown in figure it carried a uniform bent bar ABC weighing 300N/m pinned to it at C and braced by the uniform strut DE which weighs 400N. Solve for the components of the force at pin D

3 3 5 1

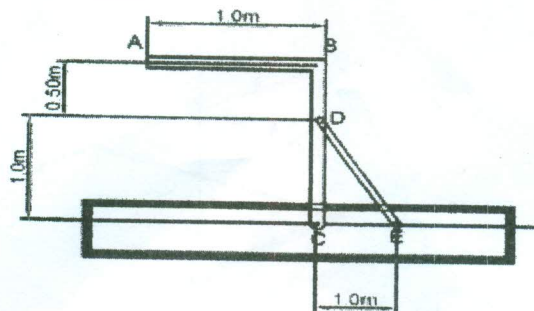

M : Marks; L: Bloom's Taxonomy Level; CO; Course Outcome; PO: Programme Outcome

i)	Blooms Taxonomy Level – 1	20%
ii)	Blooms Taxonomy Level – 2	33%
iii)	Blooms Taxonomy Level – 3 & 4	47%
